

---

# Run Length Encoding Compression on Virtual Tour Campus to Enhance Load Access Performance

Ade Bastian<sup>1</sup>, Ardi Mardiana<sup>2</sup>, Mega Berliani<sup>3</sup>, Mochammad Bagasnanda Firmansyah<sup>4</sup>

<sup>1,2,3,4</sup>Department of Informatics, Faculty of Engineering, Universitas Majalengka, Indonesia

---

## Article Info

### Article history:

Received Dec 26, 2022

Revised April 25, 2023

Accepted May 10, 2023

---

### Keywords:

Virtual Tour

Lossless Compression

Run Length Encoding

Stitching Image

Load Access

---

## ABSTRACT

Virtual tour is one of the rapidly growing applications of multimedia technology which is used for various purposes, including the dissemination of information in an interesting way. The education sector is also not spared from using virtual tour media for promotional purposes, and campuses are no exception to this rule. Large virtual tour content causes high access speed, ultimately reducing the level of comfort experienced by users. This study aims to compress panoramic images displayed on a campus virtual tour using a lossless compression method and the Run Length Encoding (RLE) algorithm. First, panoramic images are combined into one, then individual images are compressed. When recreating a virtual campus tour, compressed images are used so that the amount of data transferred is smaller. The load access speed index increases from 7,233 seconds to 3,789 seconds when images are compressed from 64 bits to 8 bits, with a compression percentage of 27%. The findings from this research are that the RLE algorithm has not been able to compress large files effectively even though it is quite successful in increasing the load access of the virtual tour website.

---

## Corresponding Author:

Ade Bastian,

Department of Informatics, Universitas Majalengka

Jl. K.H. Abdul Halim No. 103 Majalengka, Indonesia. 45418

Email: adebastian@unma.ac.id

---

## 1. INTRODUCTION

The marketing industry has been able to develop over the years to become more competitive with their rivals and also to increase the volume of potential buyers who are interested in their products. This was made possible by the growth of technology. Together with the capabilities of the internet in today's world, virtual tours have become a popular way of traveling through space or time. They have been utilized for various industries, including travel tours, viewing architecture buildings, real estate agencies, parks, and campus tours. Because prospective students might not be able to physically visit every campus before enrolling and continuing their studies, the education industry did not pass up this opportunity [1]. Virtual Tour, which has emerged as one of the most interesting and potentially useful virtual technologies in recent years, had a sizeable impact on the community-based efforts made in response to the Covid19 pandemic [2]. Virtual Reality can connect users with a virtual world which is a computer simulation, and makes them feel that they are in that world [3]. Virtual Reality-based games require additional devices to interact with the accuracy sensor values that need to be improved [4]. Virtual Reality can be used as an English language learning media for job interview preparation [5]. The university has made several different efforts, including creating portals and web pages, to facilitate the dissemination of this information. Nevertheless, the method of information delivery, which consists of the display and delivery of static text and graphics, is not very effective [6]. Technology that is able to incorporate two-dimensional or three-dimensional virtual objects into a real and projected environment

is Augmented Reality (AR) technology [7]. Markerless AR is a technology that displays virtual objects in the real world using GPS, a digital compass, and an accelerometer [8].

The world of multimedia is extremely competitive, and one of the qualities that this reflects is the speed with which users can download and upload various elements of multimedia, including text, sound, pictures, and animation. Especially in this day and age, when multimedia content is an absolutely necessary component of the world of the internet [9]. Increasing the speed at which online pages load is also known as optimizing page loads. Despite how important the internet is to our day-to-day lives, online sites often take a long time to load. The dependencies between resources included on a web page are likely to blame for the inefficiency and complexity of loading web pages. These relationships also cause underutilization of the client devices' central processing units and networks [10]. The user experience, often known as user experience (UX), is now one of the most talked-about topics in the business world. It also plays an important part in the success of businesses. Because of the importance of consumers to the expansion of a company, it is vital to place a strong emphasis on the aspects of the UX that may contribute to increased levels of customer contentment [11]. One of the many benefits of having a website with a quick loading speed is that it can boost conversion rates, improve a website's position in search engine rankings, and encourage users to explore the website further. The objective of the research was to identify and evaluate various free tools that are capable of determining the performance (loading and rendering speed) of a website as well as providing recommendations on how that performance can be enhanced [12]. The adoption of digital imaging technologies across virtually all industries has resulted in a rise in their level of significance [13]. There are never enough resources to go around [14]. A significant amount of research on compression algorithms has been sparked as a direct result of the requirement to effectively store ever-increasing quantities of data that are continuously generated on mobile devices [15]. Data that is already quite large can be reduced to a more manageable size so that more space can be saved on a computer. Text, photos, and videos are all types of data that can benefit from having their files compressed. Various compression algorithm techniques have advantages and disadvantages in doing a compression [16]. Color Quantization is a way of image compression, which is done by reducing the number of colors contained in the image so it can reduce the number of bits used. [17]. Large storage space as a requirement required compression to save as small as possible [18].

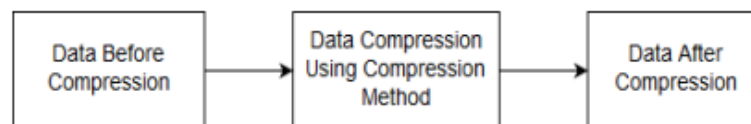

Figure 1. Data Compression

Using Figure 1, describe the steps involved in the data compression process in general. how the data when not compressed then uncompressed data will be continued and processed by a compression method that is lossless compression then, the data has been compressed will produce a size smaller than the size of the file before it is compressed when the data has been compressed will produce a size smaller than the size of the file before it is compressed how the data when not compressed then uncompressed data will be continued and processed [16]. Huffman, as one of the compression algorithm is able to reduce data storage space and speed up transmission but has disadvantages in compressing large files which makes it difficult to find similarities in bit patterns during compression and causes documents to get bigger [19]. By applying the Run Length Encoding and Lossless Compression algorithms, this study aims to improve the load access performance of the campus virtual tour website. The 360 panoramic images shown in the virtual tour go through a compositing stage, then separated into several individual images. After the image fragments have been combined, the content for the virtual tour of the campus is then reconstructed using the compressed image data. The virtual tour website is then tested for access speed to see the compression impact of the virtual tour. This study uses the RLE algorithm to compress virtual tours that have large data.

## 2. METHOD

The compression method has been selected in order to optimize the load access of the website containing the 360-degree panoramic virtual tour. Image compression refers to the process of taking an image with RGB color and compressing it using the Run Length Encoding (RLE) algorithm. After the

images have been stitched together, they are sent through a compression application that was built on the RLE algorithm, and this application is used to compress the images. Matlab-based compression and stitching of image data. When it comes time to test the image, both the original and the compressed versions are examined side by side. After that, the website that houses the virtual tour and its compressed image content is examined for load access. After the load and access performance of the website for the virtual tour has been improved, the application for the virtual tour is then hosted on the server for the website. Figure 2 provides a visual representation of the stages of the research described above.

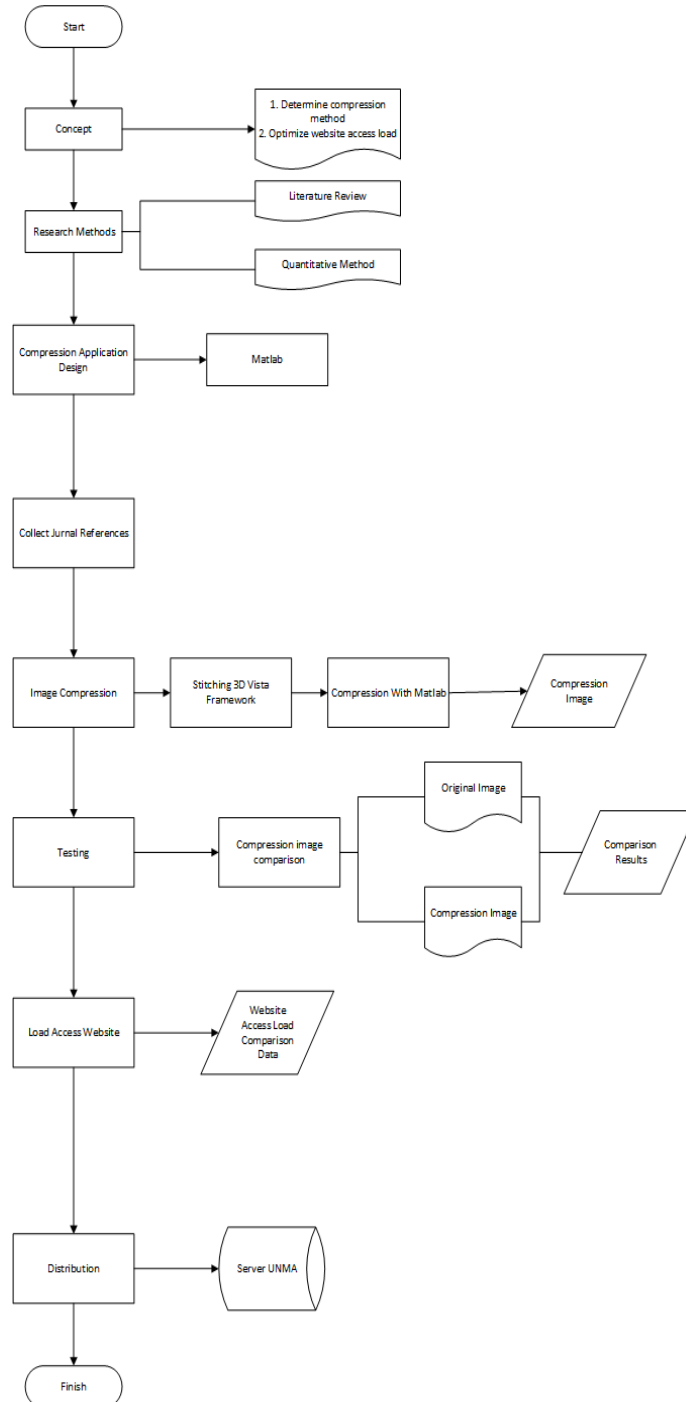

Figure 2. Research Stages

### 2.1. Lossless Image Compression

The First stage image compression, can be broken down into two distinct categories: lossy compression and lossless compression. The original image and the image that was reconstructed from it using lossy compression share a visual appearance that is very similar to one another. However, the two images are not

identical. Lossless compression, on the other hand, results in an image that is an exact replica of the source image after it has been reconstructed [20]. As the name suggests, lossy compression is characterized by the fact that these techniques result in the loss of some information during the decompression process of the compressed data. These methods can be utilized in the production of graphics, digitized images, and digitalized voices. A good number of them can be adjusted to different levels of quality, which results in greater precision in the transfer of data that has been compressed less effectively. The data are encoded and transferred without any loss of quality using lossless compression techniques. During the process of decompressing the information that was compressed, there will be no loss of data of any kind. This method is used to save database records, spreadsheets, word documents, and other types of files. In most cases, the process of data compression consists of taking a stream of symbols and converting them into corresponding codes. When you want your coding to be as efficient as possible, the code word should have fewer bits than the original stream of symbols. Certain models were responsible for making this decision [21].

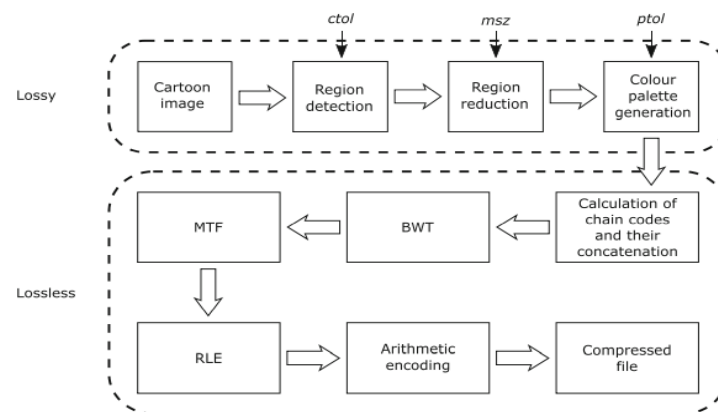

Figure 3. Run Length Encoding Method

The algorithm that has been presented operates in eight steps, which are depicted in Figure 3. The first three steps of the algorithm are considered to be lossy, while the remaining five steps are considered to be lossless. Three user-defined parameters are responsible for controlling the losses: *ctol*, *msz*, and *ptol*. Two of these parameters, *ctol*, and *ptol*, are thresholds that are used for joining colors while the region is being detected and while the palette is being calculated, respectively. The minimum size of the region that must be maintained in order for it to be considered independent following the region reduction step is specified by the *msz* parameter, which is the third parameter. In the fourth step, chain codes are used to describe each individual region. Following the concatenation of the chain codes from all of the regions, the Burrows-Wheeler Transform (BWT), Move-to-Front Transform (MTF), and Run-Length Encoding (RLE) are applied to the resulting chain. Arithmetic encoding is what's used in the very last step of the process. These steps will be broken down and discussed in greater depth in the following sections [22].

## 2.2. Run Length Encoding

Run-length encoding, also known as RLE, is a method of image compression that is always effective when applied to binary images. After predicting the Pixels and applying 3-bit instead of 8-bit as a counter to the repetition of identical consecutive pixels, RLE was used, and the result was an improvement in the compression ratio. This was accomplished using 3-bit as the counter rather than 8-bit [23]. Run Length Encoding is also used for data compression by correlating lines and columns [24]. Figure 4 illustrates the stages as well as the operation of the Run Length Encoding flowchart.

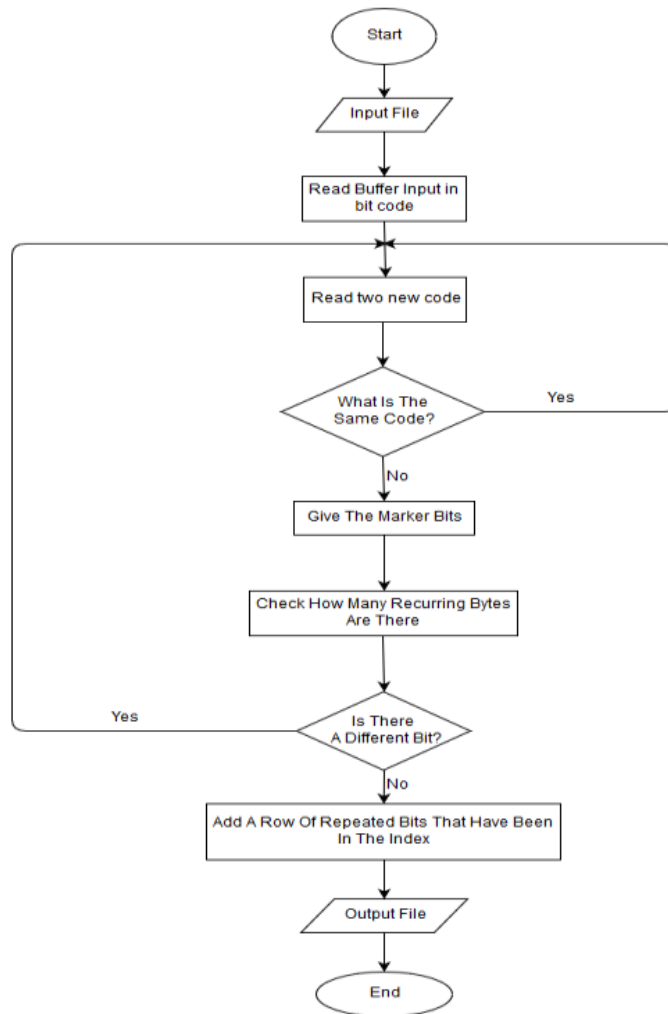
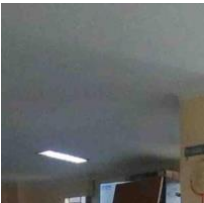
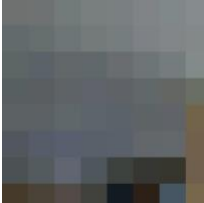

Figure 4. Run Length Encoding Flowchart

Tests should be run on compressed images, with bit depths ranging from 64 to 8, so that calculations and implementations can be simplified. For the purpose of making calculations easier, the number of compressed ratios can be calculated using image samples that have a number of bits equal to 8. The calculation for the average number of colors present in the sample image uses grayscale so that the results can be understood more easily. The rest of the calculation of full data up to 64 bits requires the assistance of a computer to calculate. The results of an example compression using RLE are shown below in Table 1.

Table 1. Image Compression Sample

No	Figure 1 (64 Bit)	Figure 2 (8 Bit)
1		

Using the RGB color hex code, the following is the calculation for the RLE (Run Length Encoding) algorithm method:

(#778899\_2), (#D3D3D3\_6)

(#778899), (#708090), (#D3D3D3\_6)

(#708090\_5), (#778899\_2), (#D3D3D3)

(#708090\_8)  
 (#708090\_2), (#D3D3D3), (#778899\_4) ), (#997950)  
 (#708090), (#778899\_4), (#D3D3D3\_2), (#997950)  
 (#), (#708090), (#A9A9A9), (#778899), (#A9A9A9)), (#808080)), (#696969)), (#997950)  
 (#3B270C), (#4B3A26), (#696969\_2) (#131E3A), (#2B1700)), (#4682B4), (#D2B48C)

64 bits multiplied by 8 bits equals 512 bits for both the initial size and the compressed size. The size that was reduced using RLE is equal to  $(42 \times 8) + (42 \times 1)$ , which equals 378. If this is the case, the number of compressed percentage ratios in the image is given as:  $(100\% - 378/512 \times 100\%) = 27\%$ . 27% is the compressed percentage ratio that uses the lossless method.

### 3. RESULTS AND DISCUSSION

After Perform a comparison using Matlab both before and after the image compression process after you have finished analyzing and calculating the image compression process using samples ranging in bit depth from 64 bits to 8 bits as an example. Figure 5 provides an illustration of Matlab-built display software for your perusal.

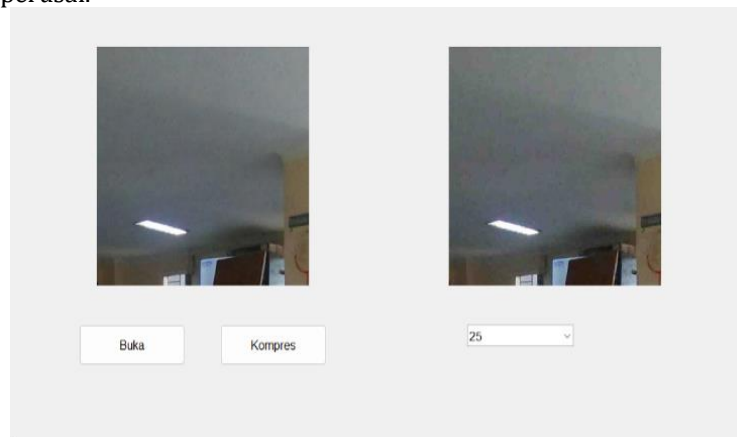

Figure 5. Run Length Encoding Software

The image compression in this scenario is carried out using a small pixel size and file size. As a result, the maximum limit for image compression is set at 50%. This is due to the fact that making the image smaller than it already is will cause damage to the image, which in turn may cause images that have been stitched by the framework to appear unclear. The specifics of the image data are presented in Table 2.

Table 2. Image Data Detail

Original Image	Image Compression
512 pixel	512 pixel
96 dpi	96 dpi
24 bit depth	24 bit depth
20,3 KB size	10,1 KB size (50,2 % reduce)

Figure 6 is an infographic that compares the outcomes of image compression using RLE to the compression ratio achieved using 8 bits.

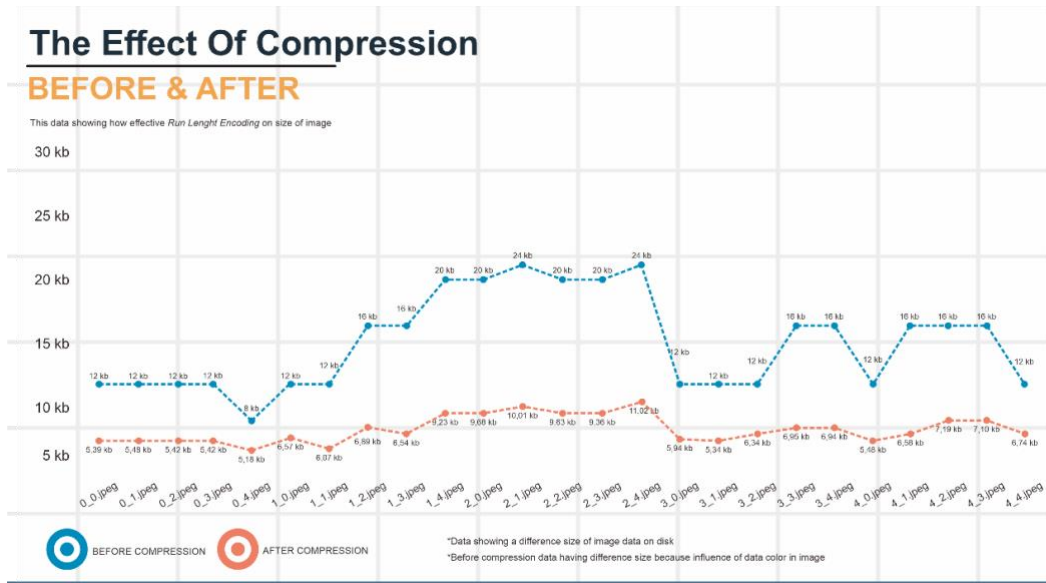

Figure 6. Run Length Encoding Method

When applied to panoramic Virtual Tour images that have been stitched into several smaller images, the impact of RLE compression, which produces well-compressed images, is applied to produce well-compressed images. The pixel count, dot per inch, and bit depth have all remained unchanged despite the size having been cut by more than half.

A comparison of the Load Access website's Virtual Tour before and after the panoramic image is compressed using the RLE algorithm and the Matlab program can be seen in Figures 7 and 8, which can be found below.

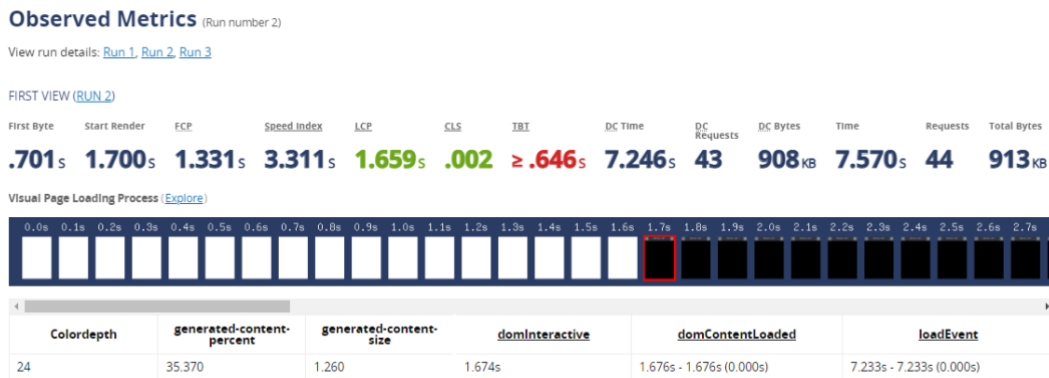

Figure 7. Load Access Time Before Compression

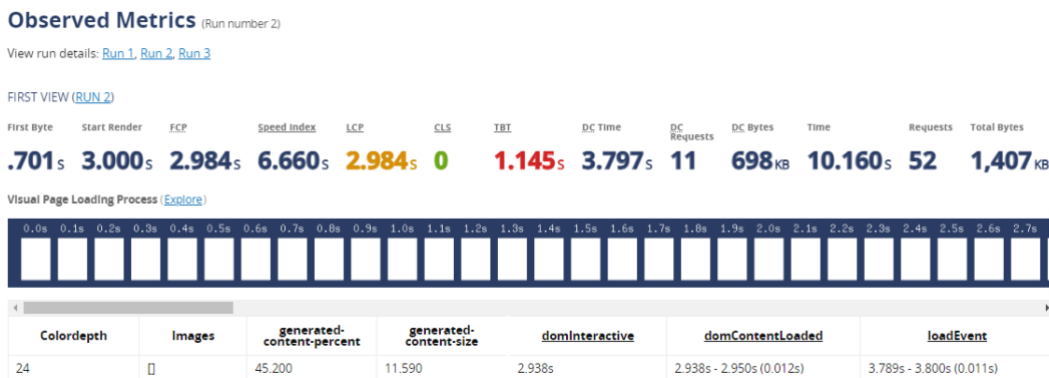

Figure 8. Load Access Time After Compression

Before the website for the virtual tour of the campus was compressed, the results of the webpage performance test showed an average time of displaying web page parts or a speed index of 3.311 seconds, a Largest Contentful Paint (LCP) of 1.659 seconds, a Cumulative Layout Shift (CLS) of 0.002 seconds, a Total Blocking Time (TBT) of above 0.646 seconds, and a Total Byte count of 913 kilobytes. The performance of the website for the virtual tour of the campus after compression results in a speed index of 6.660 seconds, LCP 2.984 seconds, CLS 0 seconds, TBT 1.145 seconds, and Total Bytes of 1,407 kb.

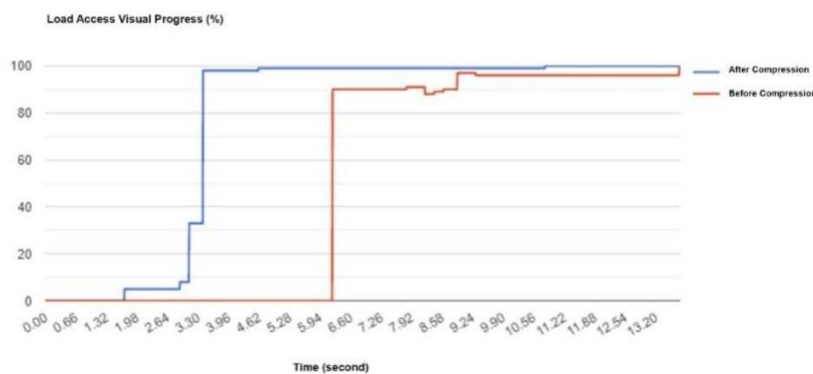

Figure 9. Load Access (%)

In Figure 9, you'll see a comparison of the load access time before and after compression, expressed as a percentage difference. After the compression process, the range of time it takes to access a website is between 1.32 seconds and 1.98 seconds, whereas before the compression process, the range was between 5.94 seconds and 6.60 seconds.

#### 4. CONCLUSION

Run Length Endocing (RLE) is adequate for compressing photos with a single dominant color, but it is ineffective for compressing images with numerous color variations. The findings of the Lossless method's image compression ratio with the Run Length Encoding Algorithm in Matlab are determined to be no more than 30% in order to preserve data and information in the image so that its quality is not diminished. In contrast, manual computations yield an average ratio of 14.9% of the total value calculated. Image compression with the Run Length Encoding (RLE) approach can reduce file size, so conserving storage space, and the lossless method serves its intended function, in that it does not dramatically degrade image quality. After compressing the image on the UNMA-360 website, load access results are much improved. Before compression, the webpage would load in 7.233 seconds; after compression, it would load in 3.789 seconds. The results of these statistics show that website optimization for virtual tour has achieved its goals. Due to the lack of the RLE Algorithm which is not efficient in compressing, future research uses the Variable Length Encoding compression algorithm to increase effectiveness and avoid data loss after the compression process [25].

#### ACKNOWLEDGEMENTS

This research was supported by Universitas Majalengka. We thank our colleagues from Universitas Majalengka who have collaborated in taking 360° panoramic images for virtual tour compression materials.

#### REFERENCES

- [1] Rizawati Binti Rohizan et al. 2019 J. Enchanced Visitor Experience Through Campus Virtual Tour. Phys.: Conf. Ser. 1228 012067. DOI 10.1088/1742-6596/1228/1/012067
- [2] Anita, Tiurida & Wijaya, Lianna & Saratiani, Athea & Kusumo, Elang & Santi,. 2021. Smart Tourism Experiences: Virtual Tour on Museum. Conference: the 11th Annual International Conference on Industrial Engineering and Operations Management.
- [3] Gema Kharismajati, Rusydi Umar, & Sunardi. 2021. Promotion of Purbalingga Tourism Object Using Augmented Reality Location Based Service & Virtual Reality 3600 Based on Android. JUITA: Jurnal Informatika Vol. 9 No. 2 pp. 229-237. DOI:



- 10.30595/juita.v9i2.9857
- [4] Atoir, F. Z. A., Putrada, A. G. ., & Pahlevi, R. R. (2021). An Evaluation of Complementary Filter Method in Increasing the Performance of Motion Tracking Gloves for Virtual Reality Games. *Kinetik: Game Technology, Information System, Computer Network, Computing, Electronics, and Control*, 6(2). <https://doi.org/10.22219/kinetik.v6i2.1234>
  - [5] Anggoro, P. (2020). Design of Web Virtual Reality for Job Interview Preparation Simulation. *Lontar Komputer : Jurnal Ilmiah Teknologi Informasi*, 11(3), 132-143. doi:10.24843/LKJITI.2020.v11.i03.p02
  - [6] Buana, W., Meily, S., & bin MD. Fudzee, M. (2021). Augmented Reality Application using Dynamic Location-Based Tracking of Taman Ayun Temple. *Lontar Komputer : Jurnal Ilmiah Teknologi Informasi*, 12(1), 24-32. doi: 10.24843/LKJITI.2021.v12.i01.p03
  - [7] Tommy, T., Siregar, R., Elhanafi, A., & Lubis, I. (2021). Implementasi Color Quantization pada Kompresi Citra Digital dengan Menggunakan Model Clustering Berdasarkan Nilai Max Variance pada Ruang Warna RGB. *Jurnal Teknologi Informasi dan Ilmu Komputer*, 8(6), 1099-1106. doi: <http://dx.doi.org/10.25126/jtiik.2021863490>
  - [8] Tengku Wook, Tengku Siti Meriam Tengku Wook & Zairon, Intan & Ashaari, Noraidah & Idris, Mushrifah & Mat Zin, Nor Azan & Judi, Hairulliza & Jailani, Norleyza. 2018. Campus Virtual Tour Design to Enhance Visitor Experience and Interaction in a Natural Environment. *The International journal of Multimedia & Its Applications*. 10. 77-92. 10.5121/ijma.2018.10307
  - [9] Abu-Taieh, Evon, Issam AlHadid. 2018. CRUSH: A New Lossless Compression Algorithm. *Modern Applied Science Vol. 12 No. 11*. DOI:10.5539/mas.v12n11p406
  - [10] Ruamviboonsuk, Vaspol. 2020. Understanding and Improving the Performance of Web Page Loads. *Computer Science and Engineering, University of Michigan*.
  - [11] Marang, A. Z. 2018. Analysis of web performance optimization and its impact on user experience (Dissertation). Retrieved from <http://urn.kb.se/resolve?urn=urn:nbn:se:kth:diva-231445>
  - [12] Kinnunen, Matias. 2020. Evaluating and improving web performance using free-to-use tools. *JULTIKA University of Oulu repository page 55*. <http://urn.fi/URN:NBN:fi:oulu-202005191965>
  - [13] H. Salman, Nassir, Enas Kh. Hassan. 2019. Run Length Encoding Based Lossless MRI Image Compression Using LZW and Adaptive Variable Length Coding. *Journal of Southwest Jiaotong University Vol. 54 No. 4*, DOI : <https://doi.org/10.35741/issn.0258-2724.54.4.23>.
  - [14] Xin, G., Fan, P. 2021. A lossless compression method for multi-component medical images based on big data mining. *Sci Rep* 11, 12372 (2021). <https://doi.org/10.1038/s41598-021-91920-x>
  - [15] Mentzer, F., Gool, L.V., & Tschannen, M. 2020. Learning Better Lossless Compression Using Lossy Compression. 2020 *IEEE/CVF Conference on Computer Vision and Pattern Recognition (CVPR)*, 6637-6646.
  - [16] Fitriya, L.A. & Purboyo, Tito & Prasasti, Anggunmeka. 2017. A review of data compression techniques. *International Journal of Applied Engineering Research*. 12. 8956-8963.
  - [17] Tommy, T., Siregar, R., Elhanafi, A., & Lubis, I. (2021). Implementasi Color Quantization pada Kompresi Citra Digital dengan Menggunakan Model Clustering Berdasarkan Nilai Max Variance pada Ruang Warna RGB. *Jurnal Teknologi Informasi dan Ilmu Komputer*, 8(6), 1099-1106. doi: <http://dx.doi.org/10.25126/jtiik.2021863490>
  - [18] Muhamad Aznar Abdillah, Anton Yudhana, & Abdul Fadlil. 2021. Compression Analysis Using Coiflets, Haar Wavelet, and SVD Methods. *JUITA: Jurnal Informatika Vol. 9 No. 1 pp. 43-48*. DOI: 10.30595/juita.v9i1.8559
  - [19] Febri Dwinata Yonathan, Hefi Nasution, & Heri Priyanto. 2021. Aplikasi Pengaman Dokumen Digital Menggunakan Algoritma Kriptografi Hybrid dan Algoritma Kompresi Huffman. *Jurnal Edukasi dan Penelitian Informatika Vol. 7 No. 2*. DOI: <http://dx.doi.org/10.26418/jp.v7i2.47077>
  - [20] Hussain, A. J., Al-Fayadh, A. & Radi, N. 2018. Image compression techniques: A survey in lossless and lossy algorithms. *Neurocomputing* 300, 44-69 (2018).
  - [21] Harika Devi Kotha et al. 2019 *J. Phys.: Conf. Ser.* 1228 012007. DOI 10.1088/1742-6596/1228/1/012007
  - [22] Jeromel, A., Žalik, B. 2020. An efficient lossy cartoon image compression method. *Multimed Tools Appl* 79, 433-451 (2020). <https://doi.org/10.1007/s11042-019-08126-7>
  - [23] Waleed, Hayder & Awheed Jeiad, Hassan & Al Salam, Mohammed. 2021. Lossless Video Compression Using Prediction and RLE. *Xi'an Jianzhu Keji Daxue Xuebao/Journal of Xi'an University of Architecture & Technology*. XII. 44-50.
  - [24] Nuha, H Hilal. 2019. Lossless Text Image Compression using Two Dimensional Run Length Encoding. *JOIN (Journal Online Informatika) Volume 4 No. 2 December 2019 75-87*. UIN Sunan Gunung Djati Bandung. DOI <https://doi.org/10.15575/join.v4i2.330>
  - [25] Rivaldo, R., Handrizal, H., & Herryance, H. (2021). Pengamanan Pesan Menggunakan Metode MLSB PRNG dan Kompresi File dengan Algoritma RLE pada File Audio. *JSINBIS (Jurnal Sistem Informasi Bisnis)*, 11(1), 1-8. <https://doi.org/10.21456/vol11iss1pp1-8>